

Standard Graphic LCD Module

PSG19264A

Feature

1. Dot Format (192 x 64)
2. 8-Bit parallel bus interface
3. Built-in LCD controller (KS0107 & KS0108)
4. Wide operating temperature range (Option)
5. High contrast ratio
6. LED or EL Backlight (Option)
7. Built-in negative voltage circuit (Option)



Mechanical Figure

Unit: mm

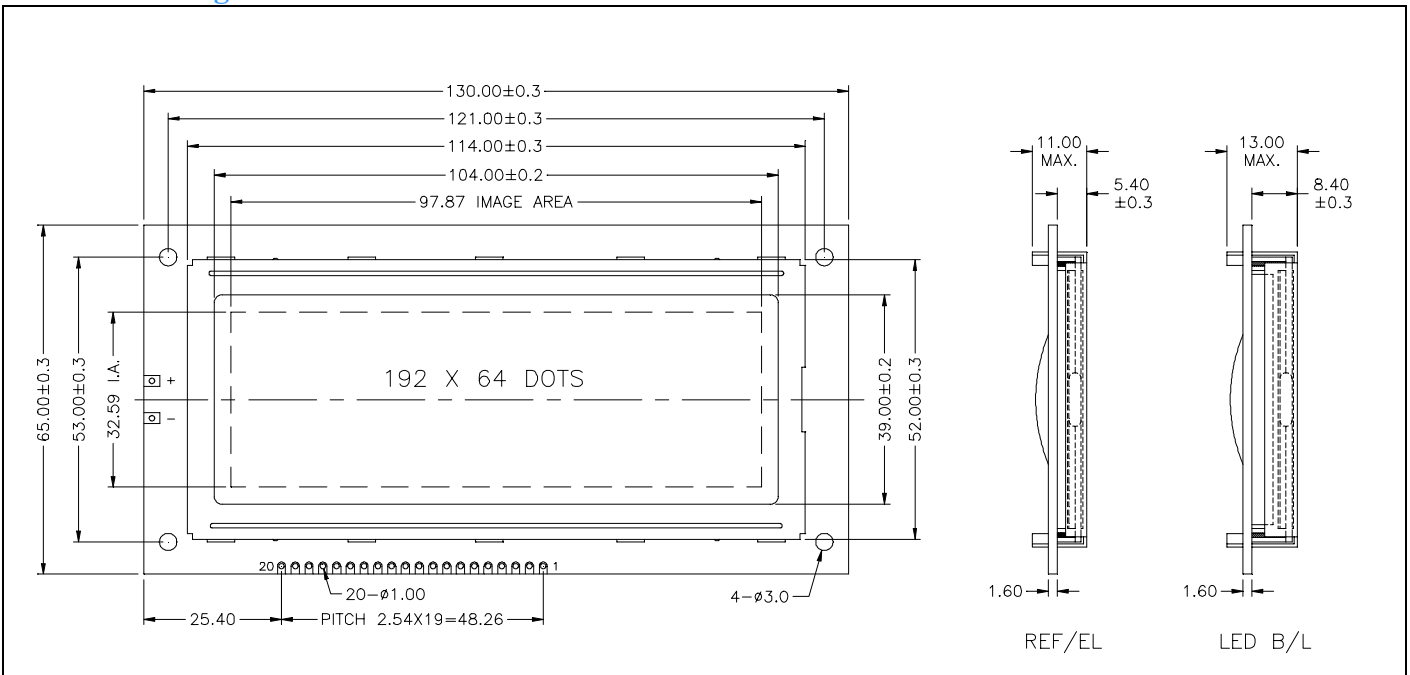

Block Diagram

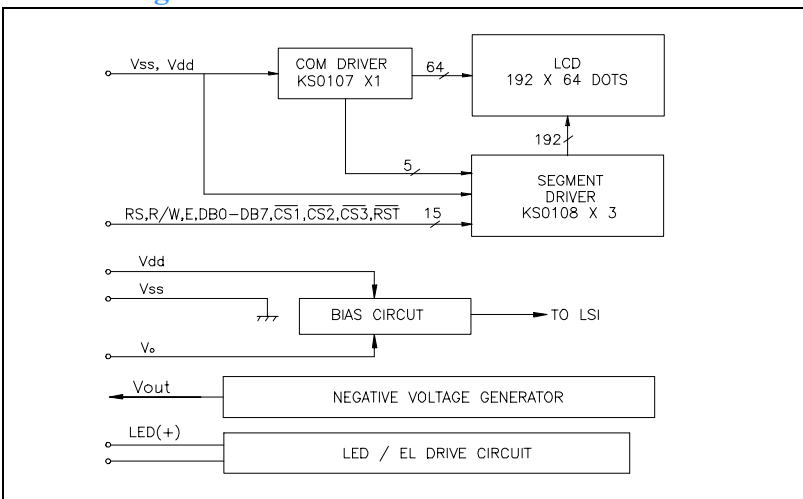

Dots Size

Unit: mm

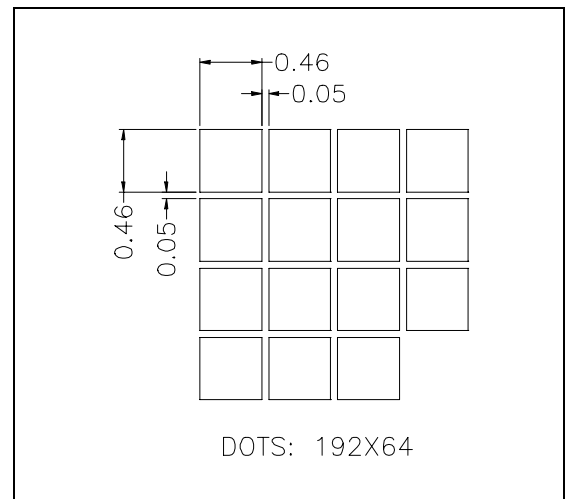

Specification

ITEM	Standard Value	Unit
Number of dots	192x64 Dots	-
Module Dimension	130.0(W)x65.0(H)x11.0/13.0(T)	mm
Viewing Area	104.0 (W)x 39.0 (H)	mm
Dot Size	0.46 (W)x 0.46 (H)	mm
Dot Pitch	0.51 (W)x 0.51 (H)	mm
LCD Type	STN	
Driver Method	1/64 Duty , 1/ 9 Bias	
Viewing Direction	6 O'clock	
Controller IC	KS0108 (Equivalent)	

Example of Power Supply

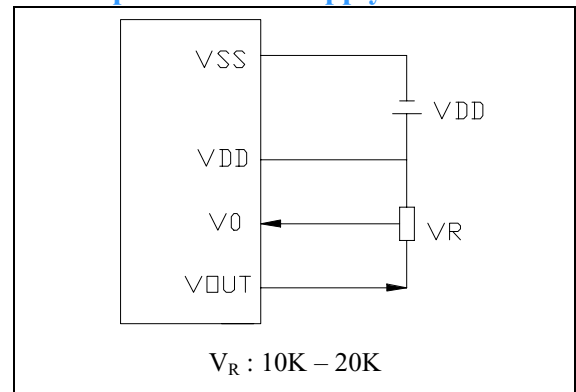

Absolute Maximum Ratings

ITEM	Symbol	MIN.	TYP.	MAX.	Unit
Operating Temperature	T_{op}	-20	-	+65	C
Storage Temperature	T_{ST}	-20	-	+70	C
Input Voltage	V_I	-0.3	-	$V_{DD}+0.3$	V
Supply Voltage For Logic	$V_{DD}-V_{SS}$	-0.3	-	7.0	V
Supply Voltage For LCD	$V_{DD}-V_5$	-0.3	-	14.0	V

Electrical Characteristics

ITEM	Symbol	Condition	MIN.	TYP.	MAX.	Unit
Supply Voltage For Logic	$V_{DD}-V_{SS}$	$T_a=25^\circ C$	-	5.0	5.5	V
Supply Voltage For LCD	$V_{DD}-V_{EE} (V_{OP})$		9.0	10.5	14.0	V
Input High Voltage			$0.8 V_{DD}$	-	V_{DD}	V
Input Low Voltage			0	-	$0.2 V_{DD}$	V
Output High Voltage		$I_{OH}=-0.5mA$	$0.8 V_{DD}$	-	V_{DD}	V
Output Low Voltage			0	-	$0.2 V_{DD}$	V

Pin Assignment

Pin Assignment				Value			Unit
Pin	Symbol	Level	Function	MIN.	TYP.	MAX.	
1	V_{SS}	0V	Power Supply (GND)	0			
2	V_{dd}	+5V	Power Supply (+5V)	4.5	5.0	5.5	V
3	V_0	-	Contrast Adjust Voltage	-	-	-	V
4	RS	H/L	Data or Instruction				
5	R/W	H/L	Data Read/Write				
6	E	H/L	Enable Signal				
7	DB0	H/L	Data Bus				
8	DB1	H/L					
9	DB2	H/L					
10	DB3	H/L					
11	DB4	H/L					
12	DB5	H/L					
13	DB6	H/L					
14	DB7	H/L					
15	/CS1	L	Chip Select IC1				
16	/RST	L	Reset Signal				
17	/CS2	L	Chip Select IC2				
18	/CS3	L	Chip Select IC3				
19	V_{out}	-10v	Negative Voltage Output				
20	LED(+)	-	LED Backlight (+) / EL	3.95	4.15	4.35	V