

Standard Graphic LCD Module

PSG128128A

Feature

1. Dot Format (128 x 128)
2. 8-Bit parallel bus interface
3. Built-in LCD controller (T6963)
4. Wide operating temperature range (Option)
5. High contrast ratio
6. LED or EL Backlight (Option)
7. Built-in negative voltage circuit (Option)



Mechanical Figure

Unit: mm

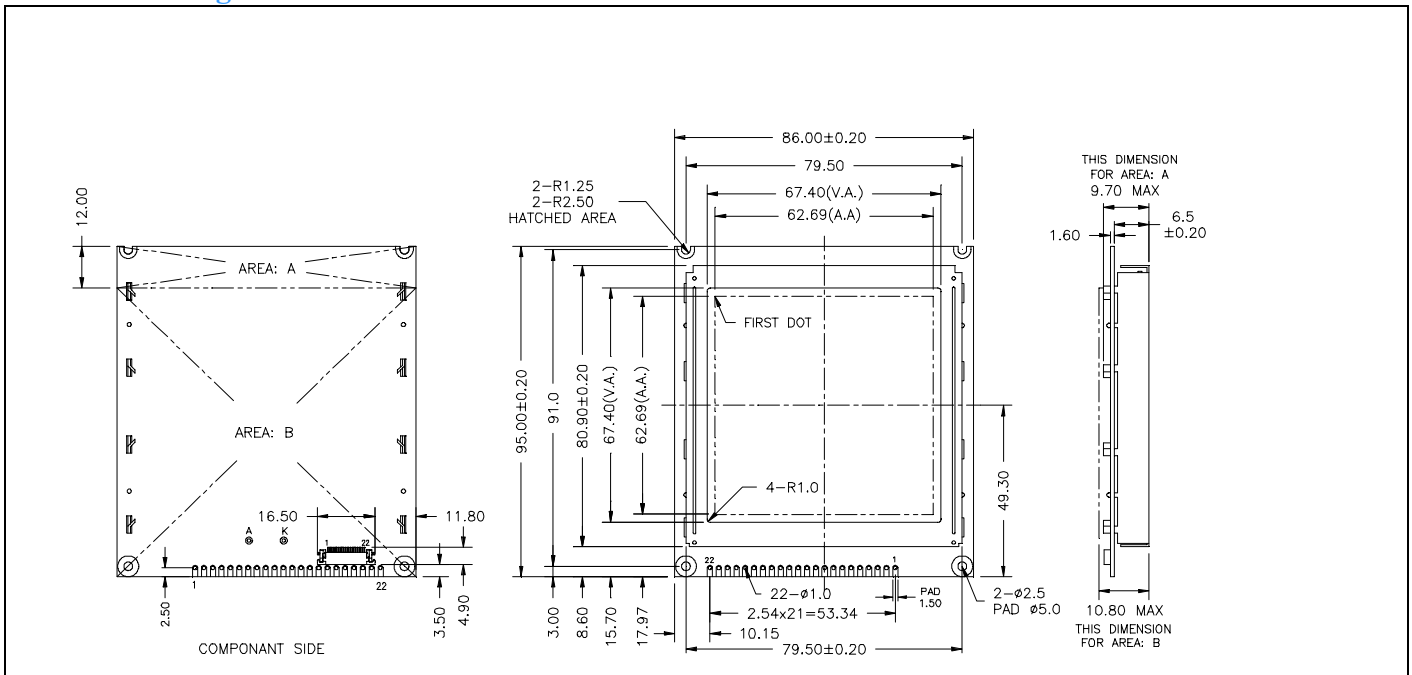

Block Diagram

Dots Size

Unit: mm

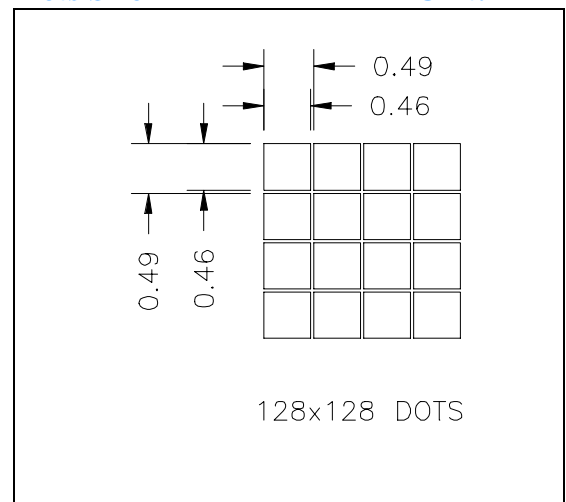
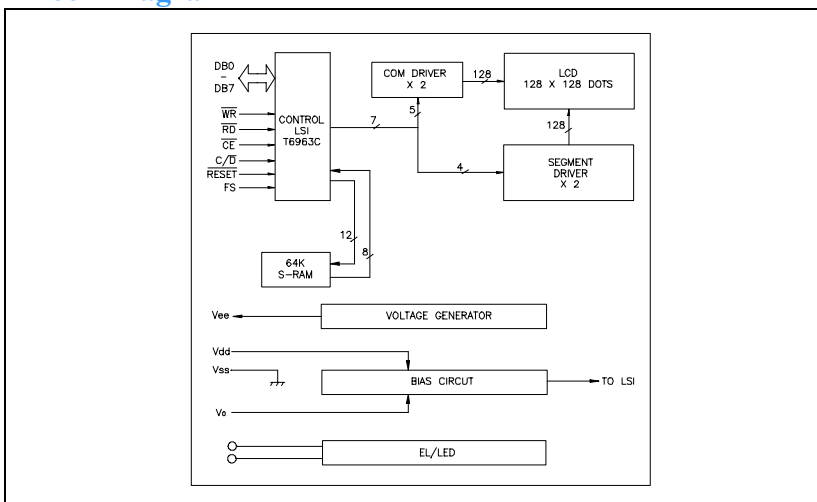

Specification

ITEM	Standard Value	Unit
Number of dots	128x128 Dots	-
Module Dimension	86.0(W)x95.0(H)x10.8	mm
Viewing Area	67.4 (W)x 67.4 (H)	mm
Dot Size	0.46 (W)x 0.46 (H)	mm
Dot Pitch	0.49 (W)x 0.49 (H)	mm
LCD Type	STN	
Driver Method	1/128 Duty , 1/ 12 Bias	
Viewing Direction	12 O'clock	
Controller IC	T6963C	

Example of Power Supply

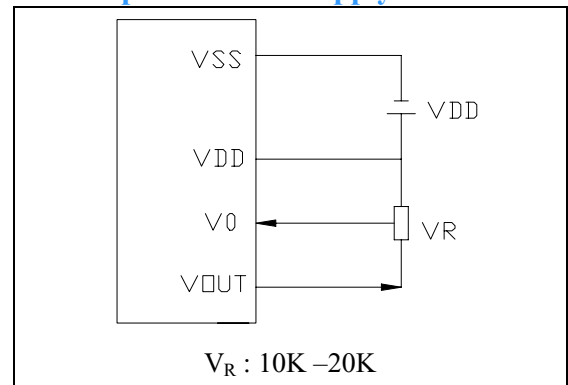

Absolute Maximum Ratings

ITEM	Symbol	MIN.	TYP.	MAX.	Unit
Operating Temperature	T_{op}	-10	-	+60	°C
Storage Temperature	T_{st}	-20	-	+70	°C
Input Voltage	V_I	-0.3	-	$V_{DD}+0.3$	V
Supply Voltage For Logic	$V_{DD}-V_{SS}$	-0.3	-	7.0	V
Supply Voltage For LCD	$V_{DD}-V_S$	-0.3	-	19.0	V

Electrical Characteristics

ITEM	Symbol	Condition	MIN.	TYP.	MAX.	Unit
Supply Voltage For Logic	$V_{DD}-V_{SS}$	$T_a=25\text{ C}$	-	5.0	5.5	V
Supply Voltage For LCD	$V_{DD}-V_{EE} (V_{OP})$		15.0	17.0	20.0	V
Input High Voltage			$0.8 V_{DD}$	-	V_{DD}	V
Input Low Voltage			0	-	$0.2 V_{DD}$	V
Output High Voltage		$I_{OH}=-0.5mA$	$0.8 V_{DD}$	-	V_{DD}	V
Output Low Voltage			0	-	$0.2 V_{DD}$	V

Pin Assignment

Pin Assignment				Value			Unit
Pin	Symbol	Level	Function	MIN.	TYP.	MAX.	
1	FG	-	Frame Ground				
2	V_{SS}		Power Supply (0V GND)		0		
3	V_{dd}		Power Supply for Logic	4.5	5.0	5.5	V
4	V_{EE}	-	NEG VOLTAGE	-	-	-	V
5	V0		CONTRAST ADJ				
6	/WR	L	WRITE SIGNAL("L" ACTIVE)				
7	/RD	L	READ SIGNAL ("L"ACTIVE)				
8	/CE	L	CHIP ENABLE SIGNAL ("L" ACTIVE)				
9	C/D	H/L-	H: Command Write/Status Read; L: Data Write/Read				
10	/RESET	H/L	Reset Signal ("L"RESET)				
11	DB0	H/L	Data Bus				
12	DB1	H/L					
13	DB2	H/L					
14	DB3	H/L					
15	DB4	H/L					
16	DB5	H/L					
17	DB6	H/L					
18	DB7	H/L					
19	FS	H/L	Font Switch				
20	NC	H/L	No Connector				
21	LED(-)	-	Power Supply for LED Backlight (-) / EL	-	2.7	3.4	V
22	LED(+)	-	Power Supply for LED Backlight (+) / EL	-	0	-	V